

General Introduction

Basic Knowledge of Regulators

A pressure reducing regulator is positioned where the high pressure of a medium needs to be reduced and maintained to a lower and stable level. By turning the adjustment handle, the tension of range spring would be changed so as to control the outlet pressure of the regulator.

Diaphragm Regulators

Major Materials of Construction

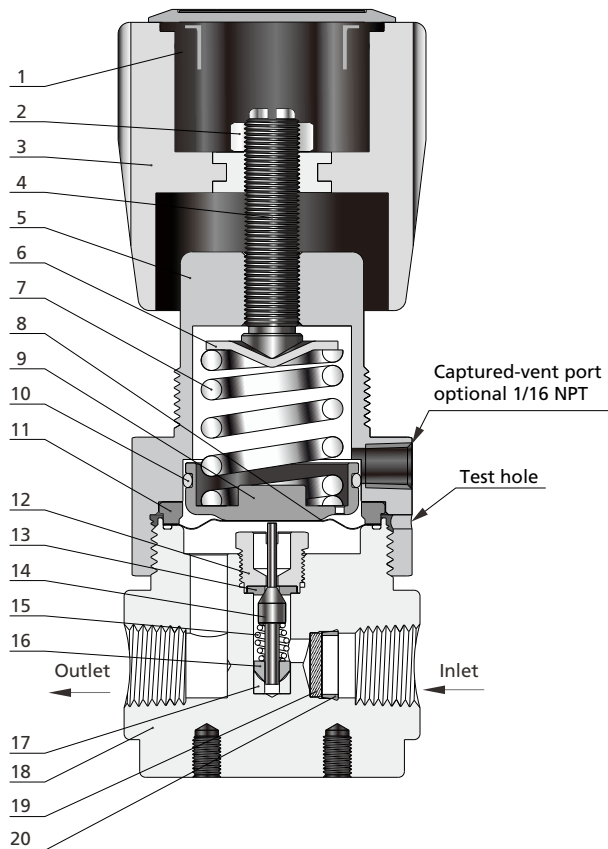

Item	Component	Material/Specification
1	Hole Plug	ABS
2	Nut	304 SS/ASTM A479
3	Knob Handle	ABS
4	Range Screw	304 SS/ASTM A479
5	Bonnet	304 SS/ASTM A479 or Brass
6	Spring Button	304 SS/ASTM A240
7	Range Spring	Alloy
8	Diaphragm	Hastelloy
9	Spring Plate	Aluminium alloy
10	O-ring	Buna-N
11	Gland	304 SS/ASTM A479
12	Seat Retainer	316L SS/ASTM A479
13	Seat	PCTFE/ASTM D1430
14	Lift Poppet	N10276/ASTM B574
15	Poppet Spring	Alloy X-750
16	Poppet Damper	PTFE/ASTM D1710
17	Friction Sleeve	316L SS/ASTM A479
18	Body	316L SS/ASTM A479 or 316 SS/ASTM A479 or Brass
19	Filter	316L SS
20	Retaining Ring	PTFE/ASTM D1710

Features

- ⦿ Metal-to-metal diaphragm seal minimizes the potential for leakage.
- ⦿ Metal diaphragm pressure sensing mechanism ensures excellent sensitivity and set point pressure stability. Piston sensing mechanism (shown on the next page) capable of withstanding higher pressures.
- ⦿ The valve stem is designed with fine threads, allowing for precise adjustment of outlet pressure with low torque.
- ⦿ Poppet damper keeps the poppet positioned accurately and reduces vibration.
- ⦿ The regulator seat is easily damaged by contaminants in the system. 40 µm filter is installed at the inlet to protect the regulator. RDGH, RDGN, RPGN and RDVC series are not fitted with filter, if there are particles in the media, a filter should be installed upstream.
- ⦿ RDGC, RDDC, RDSC, RDGH, RDGN, RDVC series diaphragm regulators are fitted with a captured-vent port through which the media can be discharged to a designated location in the event of an accidental rupture of the regulator diaphragm.

Working Principle

A pressure regulator functions by reducing high pressure media to a lower pressure. It operates by maintaining a dynamic equilibrium of forces, including the downward force on the diaphragm exerted by the range spring -- loading force (F_s), the force from the poppet spring (F_p), the inlet pressure force (F_i), and the outlet pressure force (F_o). These forces establish a balance, expressed as $F_s = F_p + F_i + F_o$. When one force changes, the other forces must adjust to reestablish balance.

When the outlet pressure (F_o) falls below the set pressure, the excess downward force pushes the poppet away from the seat, allowing more high-pressure gas to enter the chamber, thereby increasing the outlet pressure. When the outlet pressure (F_o) exceeds the set pressure, the excess upward force lifts the poppet back onto the seat, restricting the flow of high-pressure gas into the chamber and thereby reducing the outlet pressure.

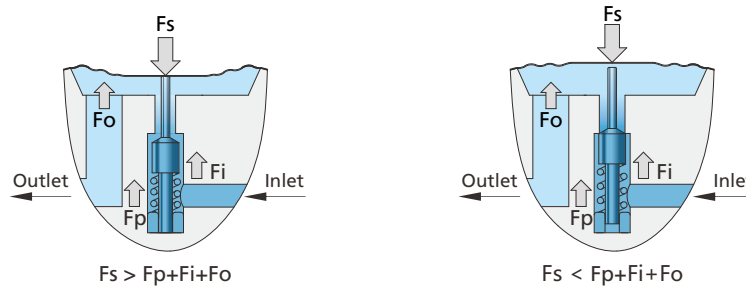

Piston Regulators

A piston regulator has the same working principle as a diaphragm regulator. The key distinction is that the diaphragm is changed to a piston to satisfy the needs for high pressure applications. Piston sensing mechanisms typically are used to regulate higher pressures than a diaphragm can withstand. They are also more resistant to damage caused by pressure spikes and have a short stroke to maximize cycle life.

Major Materials of Construction

Item	Component	Material/Specification
1	Circlips for Bores	Stainless Steel
2	Retaining Ring	PTFE/ASTM D1710
3	O-ring	FKM or FFKM
4	Piston	316L SS/ASTM A479

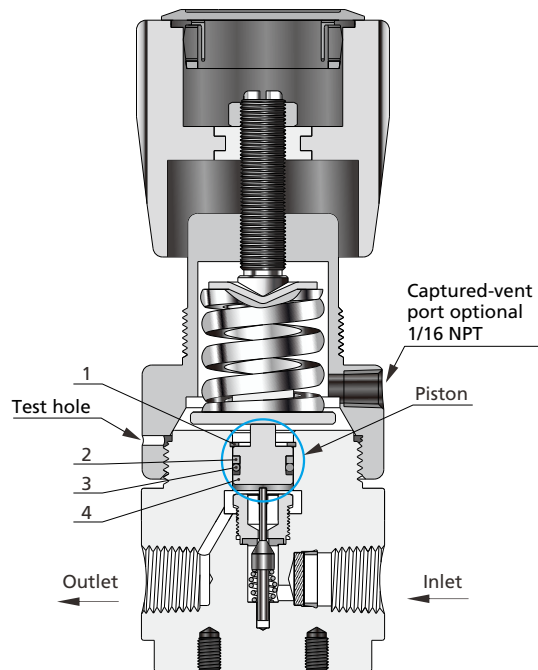

Features

- ⦿ The piston sensing mechanism can withstand higher pressures, so piston regulators have a larger outlet pressure control range.
- ⦿ RPGC series piston regulators are fitted with a captured-vent port, through which the media can be discharged to a designated location in the event of accidental failure of the piston seal of the regulators.
- ⦿ Piston regulators, except for RPCC series, are available with optional self-venting to allow excessive outlet pressure to be discharged.

Self Venting

When turning the handle counterclockwise (to DECREASE pressure), the outlet pressure in a contained system can be fully released through the self-venting mechanism, eliminating the need for an additional purge valve or bleed valve.

Principle: The valve incorporates a structure that is isolated from the atmosphere. During normal operation of the pressure regulator (INCREASE), the piston is pushed upward by the loading force from the range spring, causing the vent seat to contact the vent rod and form a seal. In this sealed state, the outlet pressure is not vented through the vent seat. When the handle is turned counterclockwise (DECREASE), the loading force from the range spring is reduced. At this point, the force exerted on the piston by the outlet pressure exceeds the loading force, causing the piston to move upward. As the piston rises, the vent rod gradually detaches from the vent seat due to its limit structure, allowing the outlet pressure to vent to the atmosphere until it reaches the new set point.

Cautions:

1. Avoid using self-venting regulators with flammable, combustible, toxic, hazardous, or corrosive media, as the self-venting process releases excess outlet pressure directly into the atmosphere. It is also not recommended for use with non-hazardous high-purity media, as self-venting may introduce atmospheric impurities into the system.
2. In certain designs, excess outlet pressure that would be vented through self-venting can be vented to a designated safe area through a captured vent port. For such requirements, please contact FITOK or our authorized distributors.
3. Since the self-venting configuration features an additional seal, considerations should be given to material compatibility, such as the seat material at the seal. Please refer to the FITOK Material Compatibility Guide on page C-05.

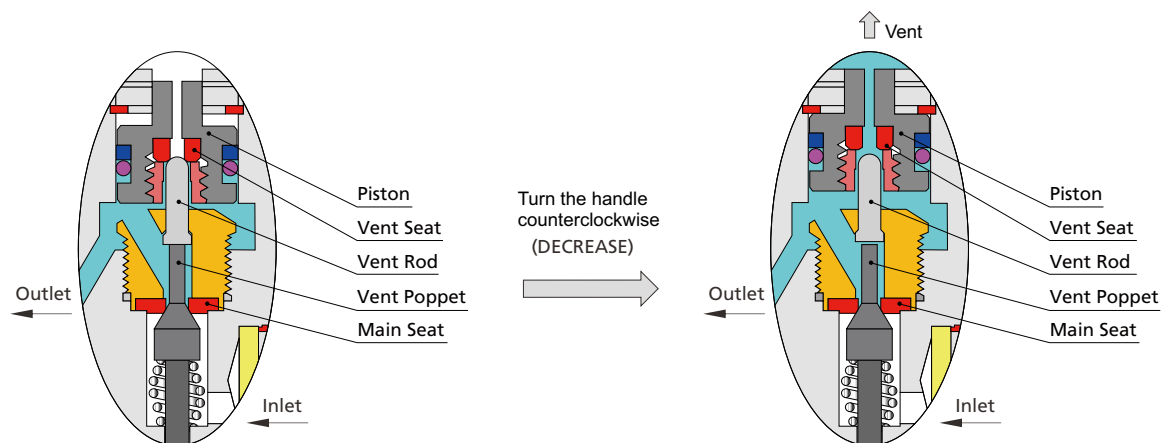

RPGC Series Self-Venting Mechanism Diagram (Media Shown in Cyan)

Note: View the corresponding animated illustration on FITOK's official website.

Dual-Stage Diaphragm Regulators

When the inlet pressure (P_i) decreases, the outlet pressure (P_o) shall increase. Even though the increase may not be significant, the dual-stage regulator would be a better option when more stable pressure is required, and the upstream pressure fluctuates violently.

The function of a dual-stage regulator is similar to that of two single-stage regulators in series. The 1st-stage regulator reduces the inlet pressure to an intermediate level for the 2nd-stage regulator to adjust to a constant output, which at the most extent ensures the stability of the outlet pressure.

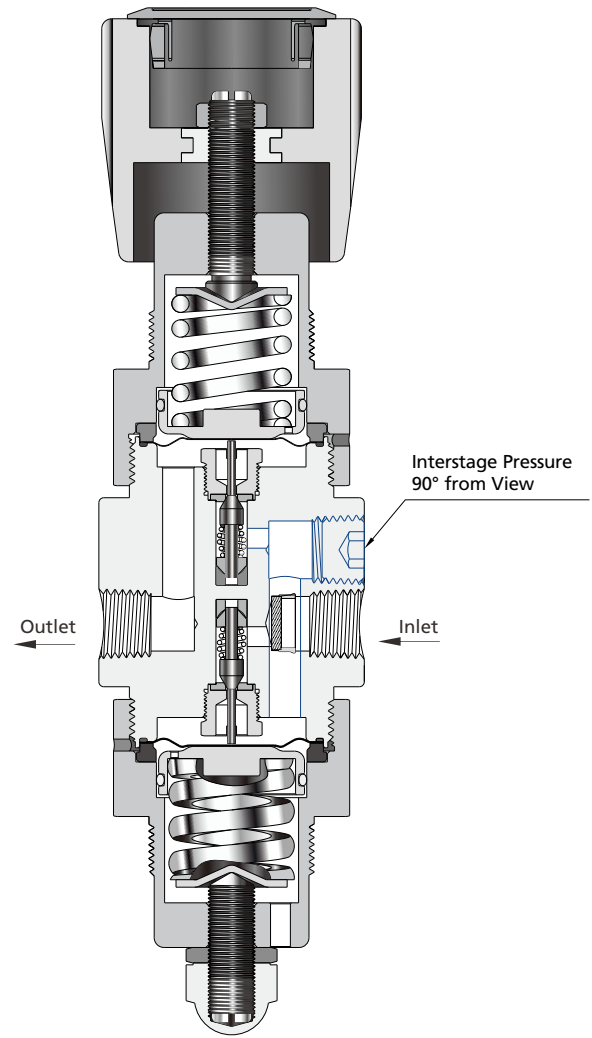
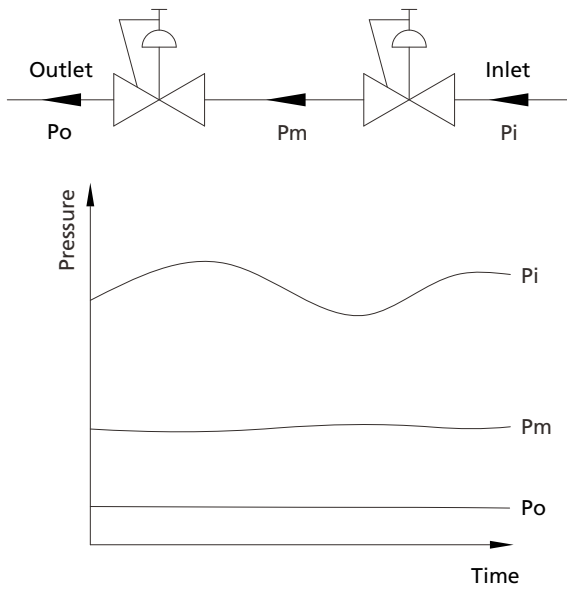

Basic Knowledge of Back Pressure Regulators

Back pressure regulators control inlet pressure by balancing an adjustable spring force against the force of the inlet pressure. The spring force is adjusted by turning the handle/stem, which sets the desired inlet pressure.

Back Pressure Diaphragm Regulators

Major Materials of Construction

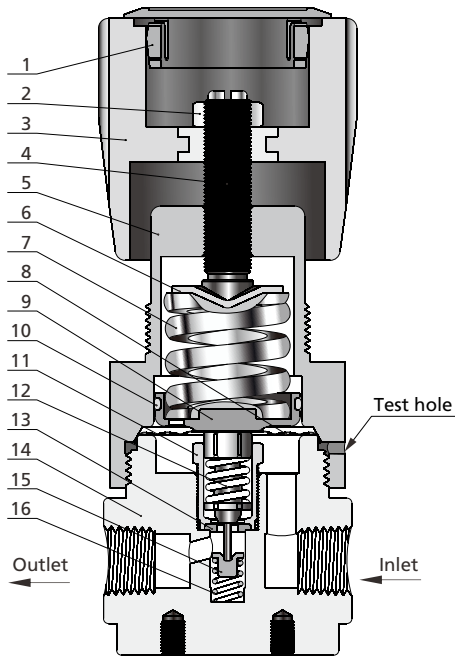

Item	Component	Material/Specification
1	Hole Plug	ABS
2	Nut	304 SS/ASTM A479
3	Knob Handle	ABS
4	Range Screw	304 SS/ASTM A479
5	Bonnet	304 SS/ASTM A479 or Brass
6	Spring Button	304 SS/ASTM A240
7	Range Spring	Alloy
8	Diaphragm	316L SS
9	Spring Plate	Aluminium alloy
10	O-ring	NBR
11	Seat Retainer	316L SS/ASTM A479
12	Lift Poppet	316L SS/ASTM A479
13	Seat	PCTFE/ASTM D1430
14	Body	316L SS/ASTM A479 or 316 SS/ASTM A479 or Brass
15	Friction Sleeve	316L SS/ASTM A479
16	Poppet Spring	316L SS/ASTM A313

Features

- ⦿ Metal diaphragm pressure sensing mechanism to ensure excellent sensitivity and stable set point pressures.
- ⦿ Stem designed with fine-pitch threads to enable precise spring adjustment with low torque.
- ⦿ Metal-to-metal diaphragm seal minimizes the potential for leakage.

Working Principle

A back pressure regulator operates on a principle similar to that of a pressure regulator. It maintains a dynamic equilibrium of forces, including the downward force on the diaphragm exerted by the range spring--loading force (F_s), the force from the poppet spring (F_p), the inlet pressure force (F_i), and the outlet pressure force (F_o). These forces establish a balance, expressed as $F_s = F_p + F_i + F_o$. When one force changes, the other forces must adjust to reestablish balance.

When the loading force (F_s) becomes lower than the combined force of the poppet spring (F_p), inlet pressure (F_i), and outlet pressure (F_o), the poppet lifts away from the seat seal, opening the path and thereby reducing the inlet pressure, where the control pressure upstream of the back pressure regulator decreases.

When the loading force (F_s) becomes higher than the combined force of the poppet spring (F_p), inlet pressure (F_i), and outlet pressure (F_o), the poppet presses against the seat seal, closing the path and thereby increasing the inlet pressure, where the control pressure upstream of the back pressure regulator rises.

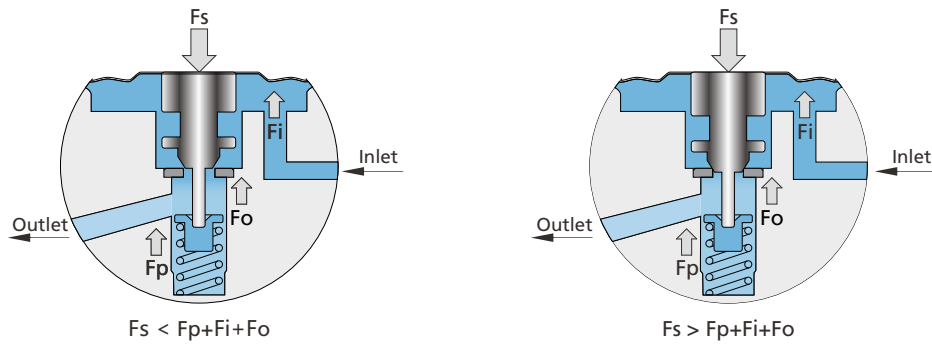

Back Pressure Piston Regulators

A piston regulator has the same working principle as a diaphragm regulator. The key distinction is that the diaphragm is changed to a piston to satisfy the needs for high pressure applications. Piston sensing mechanisms typically are used to regulate higher pressures than a diaphragm can withstand. They are also more resistant to damage caused by pressure spikes and have a short stroke to maximize cycle life.

Major Materials of Construction

Item	Component	Material/Specification
1	Body	316L SS/ASTM A479 or Brass
2	Seat	PCTFE/ASTM D1430
3	Seat Gasket	316L SS/ASTM A479
4	Seat Retainer	316L SS/ASTM A479
5	Lift Poppet	316L SS/ASTM A479
6	Piston Nut	316L SS/ASTM A479
7	O-ring	NBR or FKM or FFKM
8	Piston	316L SS/ASTM A479
9	Circlips for Bores	304 SS/GB 893.126
10	Poppet Spring	316L SS
11	Spring Plate	304 SS/ASTM A479
12	Range Spring	Alloy
13	Spring Button	304 SS/ASTM A479
14	Bonnet	304 SS/ASTM A479 or Brass
15	Range Screw	316 SS/ASTM A479
16	Nut	304 SS/ASTM A479
17	Knob Handle	ABS
18	Hole Plug	ABS
19	Label	PVC

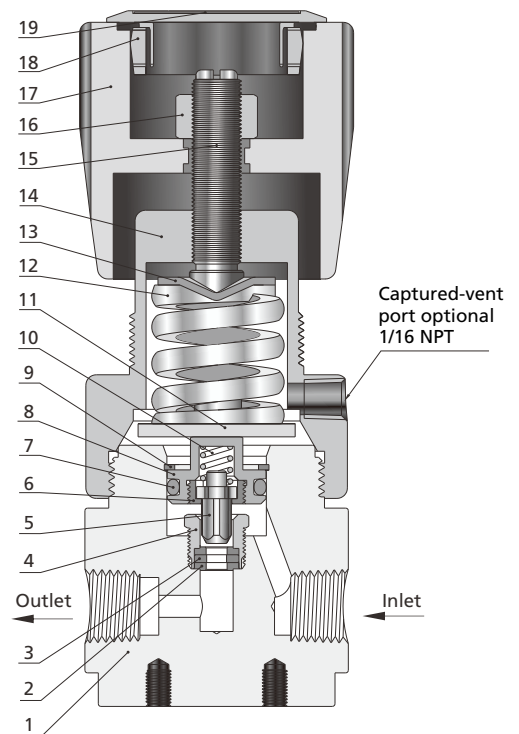

Features

- ⦿ Piston sensing mechanism can withstand higher pressures, so piston back pressure regulators have a larger inlet pressure adjustment range.
- ⦿ Stem designed with fine-pitch threads enables precise spring adjustment with low torque.
- ⦿ BPGC series piston back pressure regulators are equipped with capture-venting holes. When the piston seal of the back pressure regulator fails accidentally, the media can be released to a designated location through the Captured-vent port.

Products Range

Regulators

Regulators are typically used to reduce the high pressure in pipelines to a desired lower pressure.

Back Pressure Regulators

Back pressure regulators are used to control system back pressure and are typically used in analytical and metering systems.

Pressure Control Panels

The pressure control panels consist of a cylinder pressure regulator (RDGC or RPGC series) and a three-way diaphragm valve with cut-off, pressure reducing and vent functions. They are typically installed in gas storage areas to depressurize high pressure media from cylinders or tanks to a desired lower pressure.

Changeover Systems

The changeover system switches between the two gas sources and selects one of them to supply gas to ensure the continuity of gas consumption.

There are manual changeover system and automatic changeover system.

Manual changeover system, when a gas source is exhausted, you need to manually switch to another gas supply.

Automatic changeover system, when a gas source is exhausted, the system automatically switches to another gas supply.

Point-of-Use Panels

The point-of-use panels consist of a line pressure regulator (RDGC series or RDSC series) and a diaphragm valve with cut-off and pressure reducing functions. They are typically installed in a gas point to precisely adjust the system to a desired pressure.

Typical Application

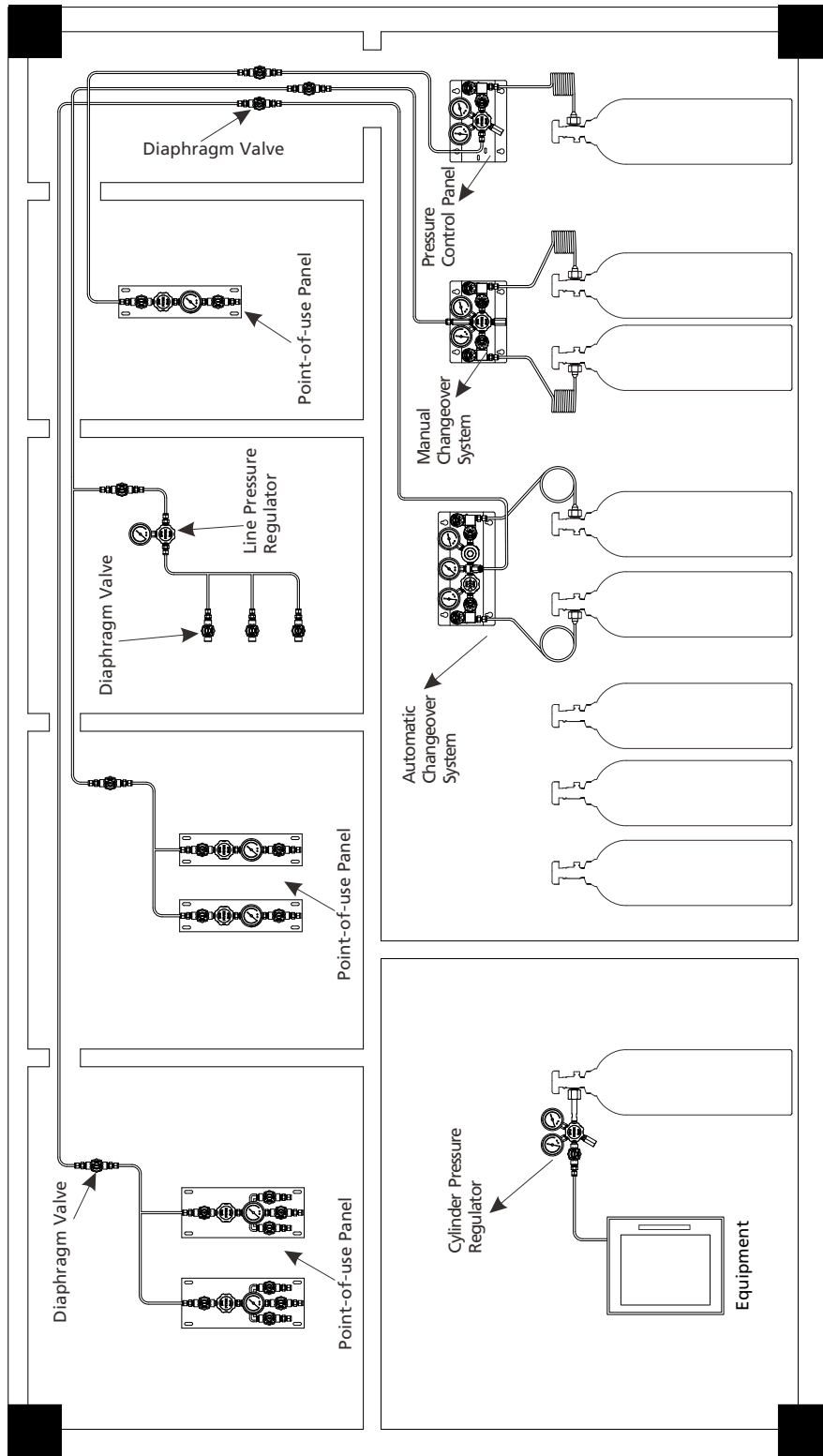

Product Selection Guide

Overview of Basic Data

Select diaphragm regulators when the outlet pressure < 500 psig.

Select piston regulators when the outlet pressure \geq 500 psig.

Dual-stage diaphragm regulators are recommended when the inlet pressure fluctuates frequently but no outlet pressure variation is desired.

Type	Series	Sensing Mechanism	Maximum Inlet Pressure (psig)	Outlet Pressure Range (psig)	Captured Vent Port	Flow Rate (Cv)
General Diaphragm Regulators	RDGC	Diaphragm	4500	0~500	Yes	0.2 (Inlet pressure 500, 1500) 0.09 (Inlet pressure 3500, 4500)
General Tied-Diaphragm Regulators	RTGC	Diaphragm	3500	0~150	Yes	0.06 (Inlet pressure 3500) 0.15 (Inlet pressure 600, 1000)
Miniature Diaphragm Regulators	RDCC	Diaphragm	150	0~100	No	0.08
Miniature Tied Diaphragm Regulators	RTCC	Diaphragm	150	0~100	No	0.08
Two-Stage Diaphragm Regulators	RDDC	Diaphragm	4500	0~250	Yes	0.06
Sensitive Diaphragm Regulators	RDSC	Diaphragm	4500	0~200	Yes	0.06
Medium Flow Diaphragm Regulators	RDGH	Diaphragm	3000	0~200	Yes	1.0
High Flow Diaphragm Regulators	RDGN	Diaphragm	500	0~150	Yes	1.8
Steam Heated Regulators	RDVC	Diaphragm	3600	0~500	No	0.06
General Piston Regulators	RPGC	Piston	6000	0~2500	Yes	0.06 0.1 (Vent)
Compact Piston Regulators	RPCC	Piston	6000	0~1800	No	0.06
High Pressure Piston Regulators	RPGX	Piston	10000	10~10000	No	0.06
High Flow Piston Regulators	RPGN	Piston	4500	0~1500	No	2.0
Back Pressure Regulators	BDGC	Diaphragm	250	0~250	No	0.3
	BPGC	Piston	1000	10~1000	Yes	0.3
	BPGX	Piston	10000	5~10000	No	0.25
Pressure Control Panels ^①	FSR-1	Diaphragm	4500	0~500	No	0.06
	FSR-2	Piston	4500	0~2500	Yes	0.06 0.1 (Vent)
Changeover Systems ^①	FDR-1	Diaphragm	4500	0~500	No	0.06
	FDR-2	Piston	4500	0~2500	Yes	0.06 0.1 (Vent)
	CEPR	Diaphragm	3000	85~265	No	0.06
	FDR-1L	Diaphragm	4500	85~265	No	0.06
	DPPR	Diaphragm	3000	0~150	No	0.06
	FDR-1T	Diaphragm	4500	0~150	No	0.06
Point-of-Use Panels ^①	FPR-1	Diaphragm	1500	0~500	No	0.14
	FPR-1S	Diaphragm	1500	0~200	Yes	0.06

Note:

① Sensing mechanism of pressure control panels, changeover systems and point-of-use panels refers to the sensing mechanism of the pressure regulator.

Pressure Gauge Ordering Information

When selecting pressure gauges for use with pressure regulators, back pressure regulators, or control systems, the relationship between the maximum scale value of the inlet/outlet pressure gauge and the working pressure is as follows:

Working Pressure vs. Maximum Gauge Scale			
Working Pressure (psig)	Max. Gauge Scale		
	Scale Unit		
	psig (primary)	MPa (secondary)	bar (secondary)
15	30	0.2	2
25	60	0.4	4
30	60	0.4	4
50	100	0.7	7
60	100	0.7	7
75	100	0.7	7
80	160	1.1	11
100	160	1.1	11
140	200	1.3	13
150	200	1.3	13
200	300	2	20
220	300	2	20
250	400	2.5	25
300	400	2.5	25
500	800	5	50
600	1000	7	70
700	1000	7	70
750	1000	7	70
800	1500	10	100
1000	1500	10	100
1200	2000	13	130
1500	2000	13	130
1800	3000	20	200
2500	4000	25	250
3000	4000	25	250
3500	6000	40	400
3600	6000	40	400
3800	6000	40	400
4000	6000	40	400
4500	6000	40	400
6000	8000	55	550
10000	15000	100	1000

Notes:

- Pressure gauge scale units are available in either psi/MPa or psi/bar, with psi as the primary unit.
- For dual-scale pressure gauges, the maximum scale value refers to the primary scale. The secondary scale is for reference only.
Example: For a gauge with a scale range up to 200 psi, the primary scale's maximum value is 200 psi, while the secondary scale (MPa) may show a corresponding value of 1.3 or 1.4 MPa.
- Pressure regulators or back pressure regulators are generally equipped with GC series pressure gauges, except in the following cases:
 - For pressure regulators or back pressure regulators with welded integral FR metal gasket face seal connections, GP series pressure gauges are used by default.
 - If the inlet pressure or control pressure exceeds 4500 psig, GA series pressure gauges are default.
 - If pressure regulators or back pressure regulators are required to comply with NACE standards, GA Series pressure gauges are used by default.
 - If the working temperature exceeds 100°C, GA series pressure gauges are used by default.
- For pressure gauges used in control systems, refer to the corresponding product catalog.
- For special requirements regarding pressure gauge series or maximum scale values, please contact FITOK or our authorized distributors.

User's Guide

1. Pressure regulators are sensitive components, so handle them gently and do not bump them.
2. Pressure regulators should not be used as shutoff valves or safety valves.
3. For non-self-venting regulators, do not turn the handle counterclockwise (DECREASE) when there is no flow of media.
 - a> If residual pressure is present at the outlet of the pressure regulator when the media is not flowing, turning the handle counterclockwise (DECREASE) can cause the residual pressure to act directly on the sensing element (diaphragm or piston), potentially leading to regulator damage.
 - b> To reduce the set pressure at the regulator outlet, adjust only when the media is flowing (i.e., when there is flow).
4. Pressure regulators with bottom mounting or panel mounting type available, when panel mounting is selected, handles of some series products need to be removed for installation. When removing the handle, ensure that the handle and stem positions are not changed, otherwise the outlet pressure range will not be the same as the factory setting.
5. Before the pressure regulators are connected to the piping system, the system must be purged to remove impurities from the system, such as iron filings from tubing cutting or welding slag from tubing welding.
6. If the media contain impurities, a filter must be installed upstream, otherwise the impurities will damage the pressure regulators, which will lead to the failure of the pressure regulating function of the pressure regulators and the continuous increase of downstream pressure. The downstream pressure will continue to rise and damage the downstream pressure gauge or other equipment. FITOK FT series 15 µm filters are recommended.
7. When installing a pressure regulator, verify the inlet and outlet. do not allow any loose thread sealing tape or thread sealant to enter the pressure regulators. If the outlet is connected to a high pressure source exceeding the outlet pressure set point, the regulator may be easily damaged.
8. After the pressure regulators are connected to the pipeline, make sure that the pressure regulators are in the closed position by turning the handle before using the pressure regulators. For pressure regulators, turn the handle counterclockwise until it is loosened to the closed position.
9. Check connections for leakage by applying leak detection fluid to all connections, turning the handle clockwise to set the outlet pressure to the desired pressure, and observing the connections for leakage.
10. If the pressure regulators are used for liquid media, the filter element installed at the inlet of the pressure regulators may clog and cause a pressure drop and flow reduction. It is recommended to remove the filter element and install a filter upstream the inlet of the pressure regulators.